

# OPI | GROUP

Opificio Progettazioni Industriali

# INCINERATORS

---



INCINERATORS

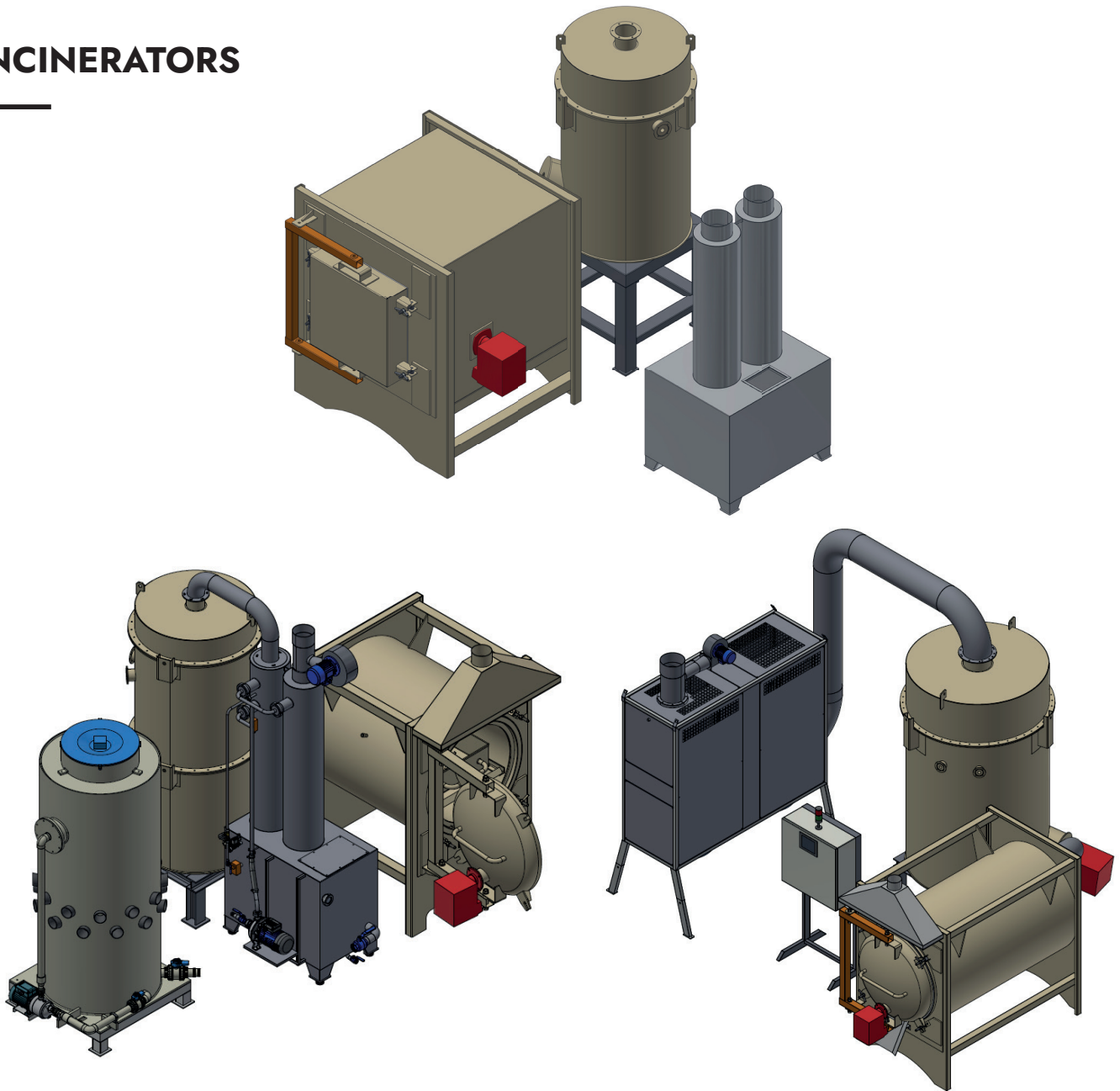

MODEL	BP01	BP04	BP16
COMBUSTION CHAMBER CAPACITY lt	150	400	800
COMBUSTOR POWER Kw	15	25	40
POST-BURNER Kw POWER	30	80	210
OVERALL DIMENSIONS mm	3000X1700XH2400	3000X3000XH2600	4800X4300XH3200

The dimensions are to be considered INDICATIVE and without stairs and/or walkways.



## FUME FILTERING SYSTEMS

The incineration system by OPI GROUP has been designed and built for gold companies in order to allow the recovery of precious metals lost during the manufacturing process. The treatment involves the incineration of processing waste or scraps from which the precious material is recovered. The plant by OPI GROUP is suitable to treat the following processing residues:

Material resulting from floor cleaning, work benches, cleaning machines recovery;

Filtered and pressed sludge from wastewater treatment plants. Small pieces of wood resulting from barrelling operations.

Our experience now allows us to meet the customers' needs related to the recovery and treatment of processing operations not related to the gold industry, such as material coming from electronic cards, button cells, etc

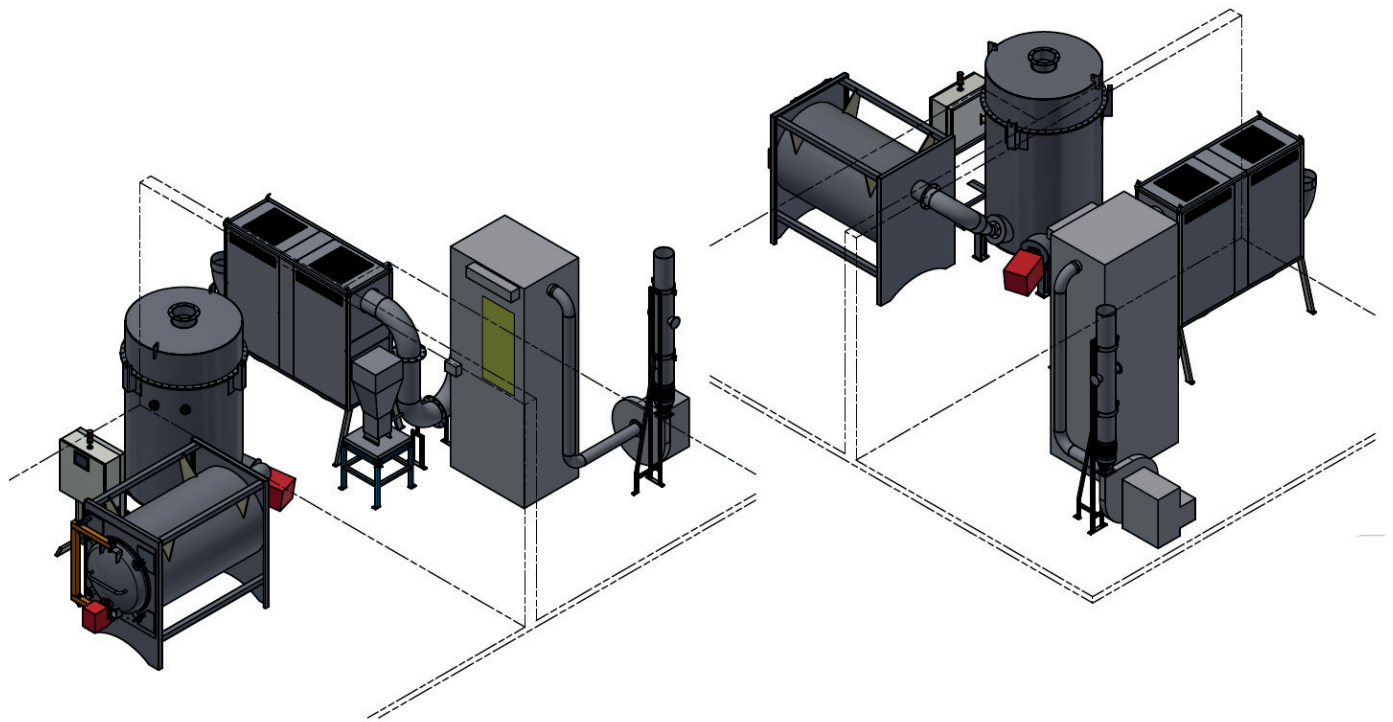

SCRUBBER

AIR-AIR HEAT EXCHANGER

SLEEVE FILTRATION

The dimensions are to be considered INDICATIVE and without stairs and/or walkways.

